

From Ph.D. to Postdoc: My Perspective

Ryan S. Kim (Fermilab)

FSPA Career Seminar Series

March 11, 2026

~2 years ago as a grad student, I distinctly remember just staring out of the WH10E windows looking at the Tevatron ring, an absolute ball of angst about myself and about my career moving forward... Am I going to finish my PhD? Am I going to stay in physics? Will I get to stay in Chicago?

I shaped this talk to be one that I wish I heard around then... :)

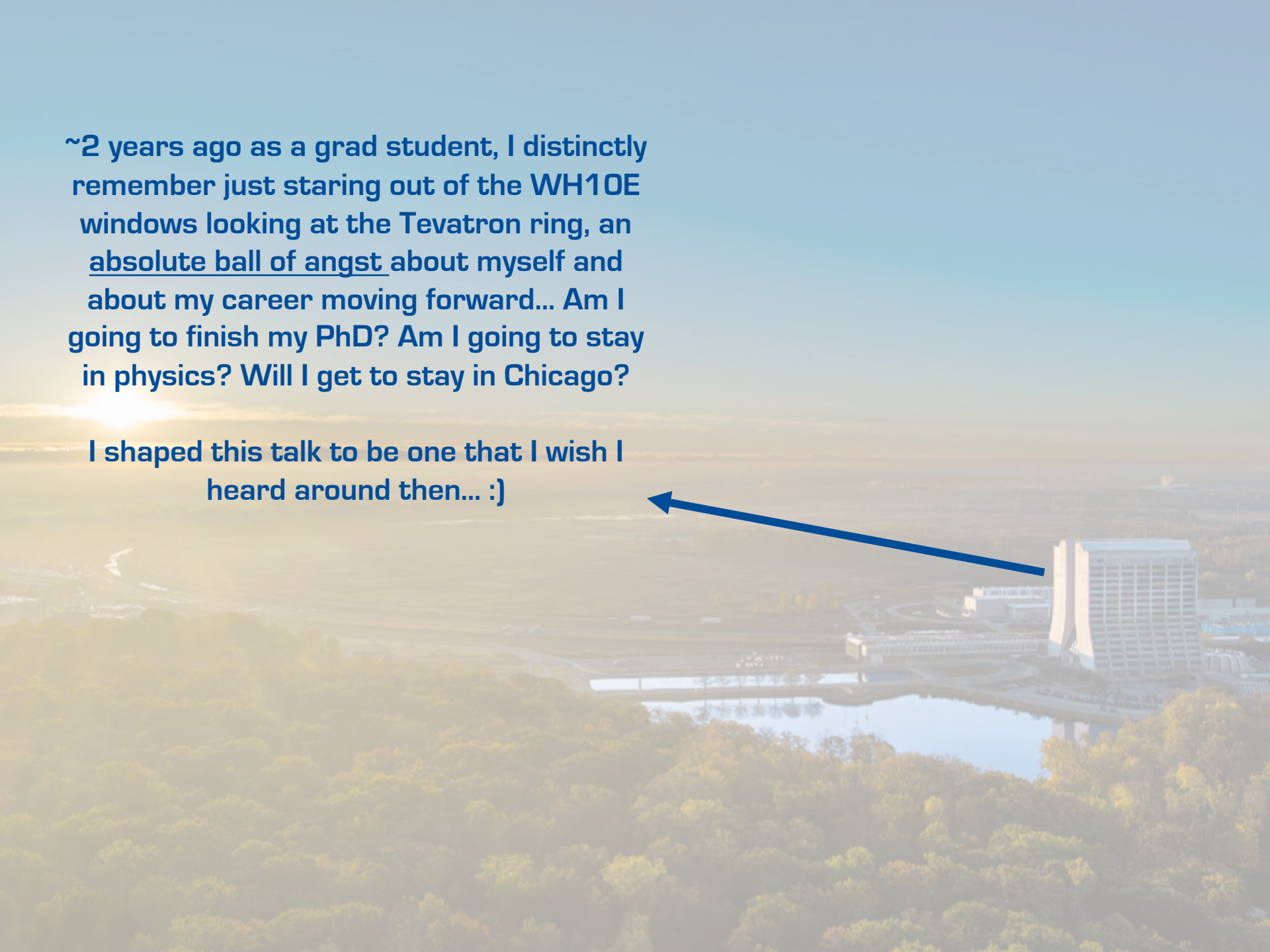

You will finish!!

... *if* you decide you want to finish

But it is A LOT of work

It's ok to feel disillusioned with the field

It's ok if you decide you don't want to finish

It's ok to explore other things you might want to do

Your worth as a person is **not** tied to your work or your research

But... most of you are here because you're at least **considering** staying in the field and **doing a postdoc**, and that's what I was asked to talk about 😊 So let's talk about the PhD → postdoc transition

But First, Quickly About Myself



B.S. in Physics Honors (2019)
Minor in Italian Language

Glynn Family Honors Program

Rome International Scholars Program

- **2016:** first project in CMS building hardware for HCAL Phase-1 Upgrade with Prof. Mitch Wayne
- **2017:** one summer working on offline radon veto in the XENON1T experiment with Prof. Rafael Lang (Purdue)
- **2017 - 2019:** CMS high- p_T photon ID with the e/γ POG working with Prof. Colin Jessop and Prof. Riccardo Paramatti (Rome Sapienza)
- **Six months in Rome** doing research and teaching at Italian high school
- Wrote undergrad **senior thesis** on high- p_T photon ID



2016: HCAL optical decoder units (ODUs)



2018: first time at CERN, at a CMS week in June



But First, Quickly About Myself



FSU
FLORIDA STATE
UNIVERSITY

M.S. in Physics (2020)

Ph.D. in Physics (2025)

FSU Hagopian Family Endowment
Award for Outstanding HEP
Student (2022)

FSU Outstanding TA Award
Nomination (2022)

Fermilab LPC Graduate Scholar
(2022)

Fermilab LPC Graduate Scholar
(2023)

URA Visiting Scholar (2024)

- **2019:** started my thesis project of searching for heavy stable charged particles (HSCPs) in CMS under guidance of Prof. Todd Adams
- **2020-2021:** COVID-19, other personal life difficulties, almost quitting grad school...
- **2022:** started as a LHC Physics Center Graduate Scholar at Fermilab! Working on HSCPs + tile module assembly for HGCal with Harry Cheung, Jim Freeman, and Daniel Guerrero
- **2023:** started working with Grace Cummings & Sergo Jindariani on HSCPs
- **Jan 2025:** applied for Lederman fellowship
- **Apr 2025:** got the Lederman fellowship!
- **Jul 2025:** married to Esther in Chicago courthouse!
- **Sep 2025:** Ph.D. defense from WH1W
- **Oct 2025:** started as Lederman fellow





The Higgs Potential

The Standard Model Higgs potential:

$$V(\phi) = -\mu^2 \phi^\dagger \phi + \lambda (\phi^\dagger \phi)^2$$

Expanding around the vacuum expectation value:

$$V(H) \supset \frac{1}{2} m_H^2 H^2 + \underbrace{\lambda_{HHH} v H^3}_{\text{Trilinear coupling}} + \frac{1}{4} \underbrace{\lambda_{HHHH} H^4}_{\text{Quartic coupling}}$$

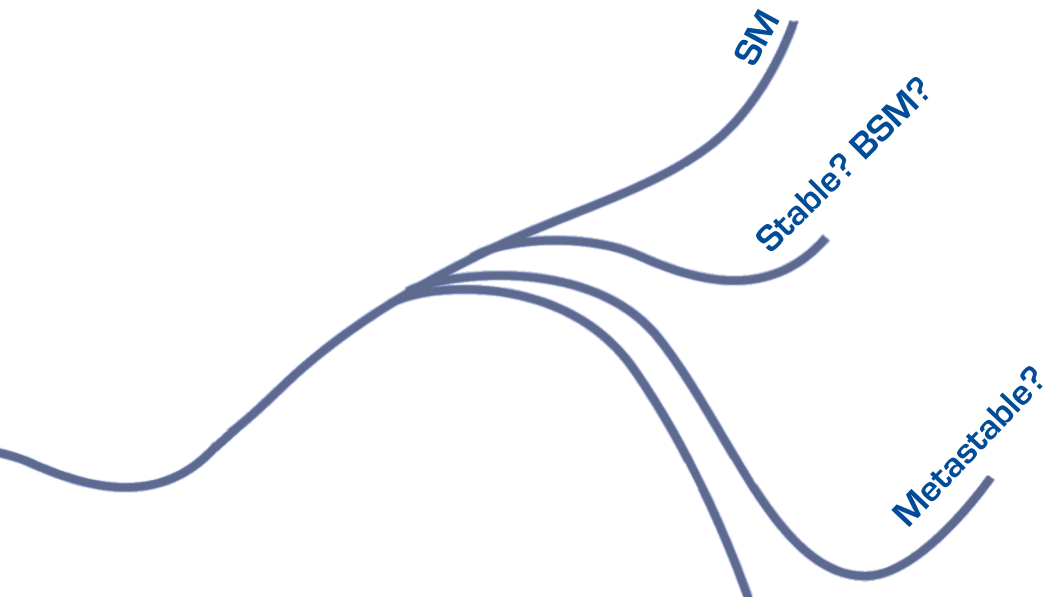

Understanding λ_{HHH} is crucial to understanding our universe!

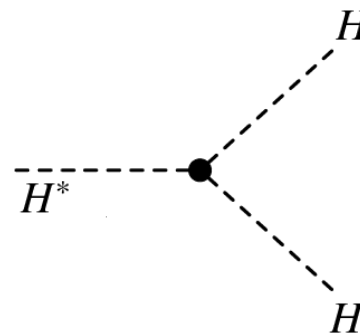



The Energy Frontier: LHC

Diagram:
Nathaniel Craig

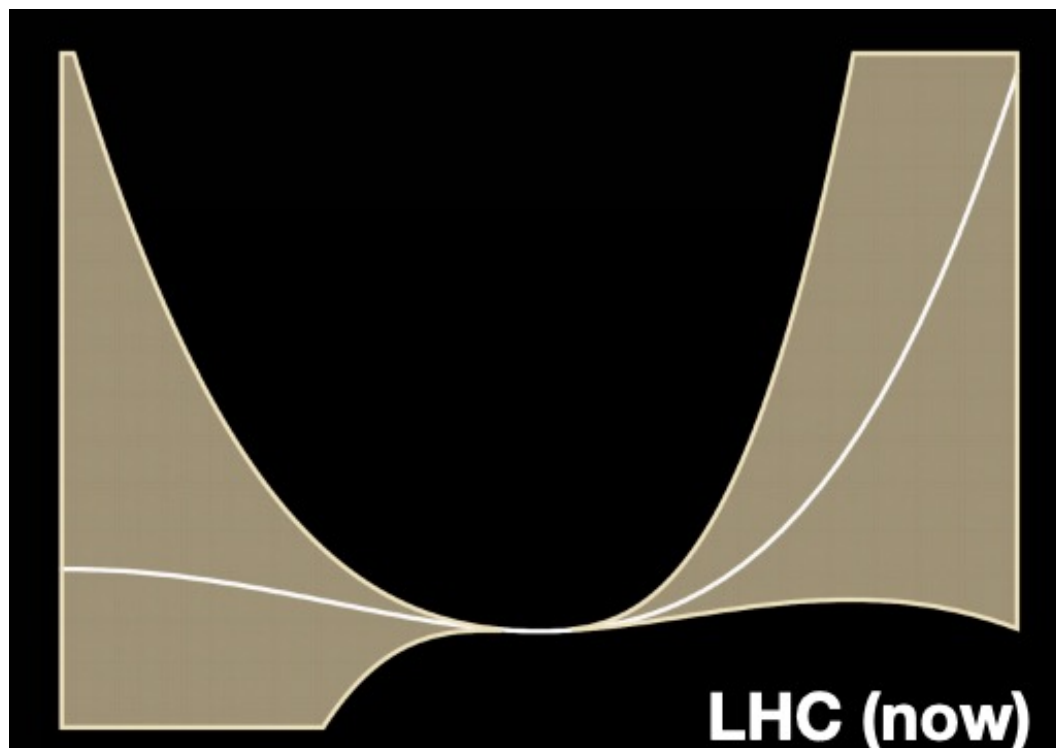

First and only experimental measurements of λ_{HHH}

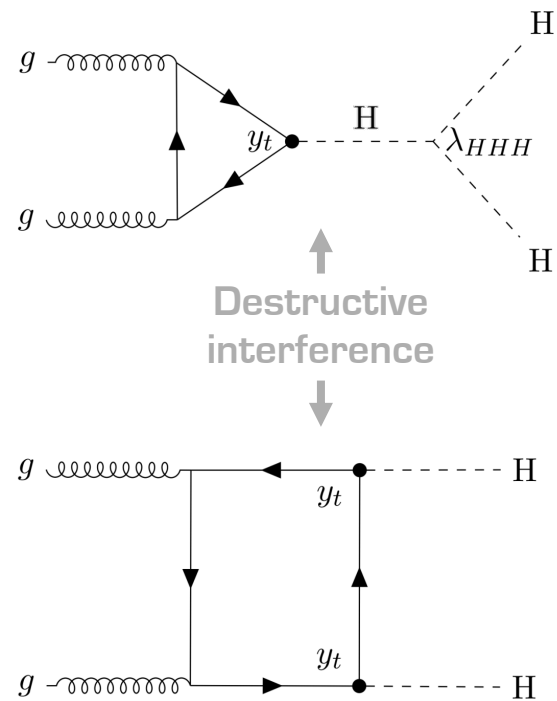

The Energy Frontier: HL-LHC

Diagram:
Nathaniel Craig

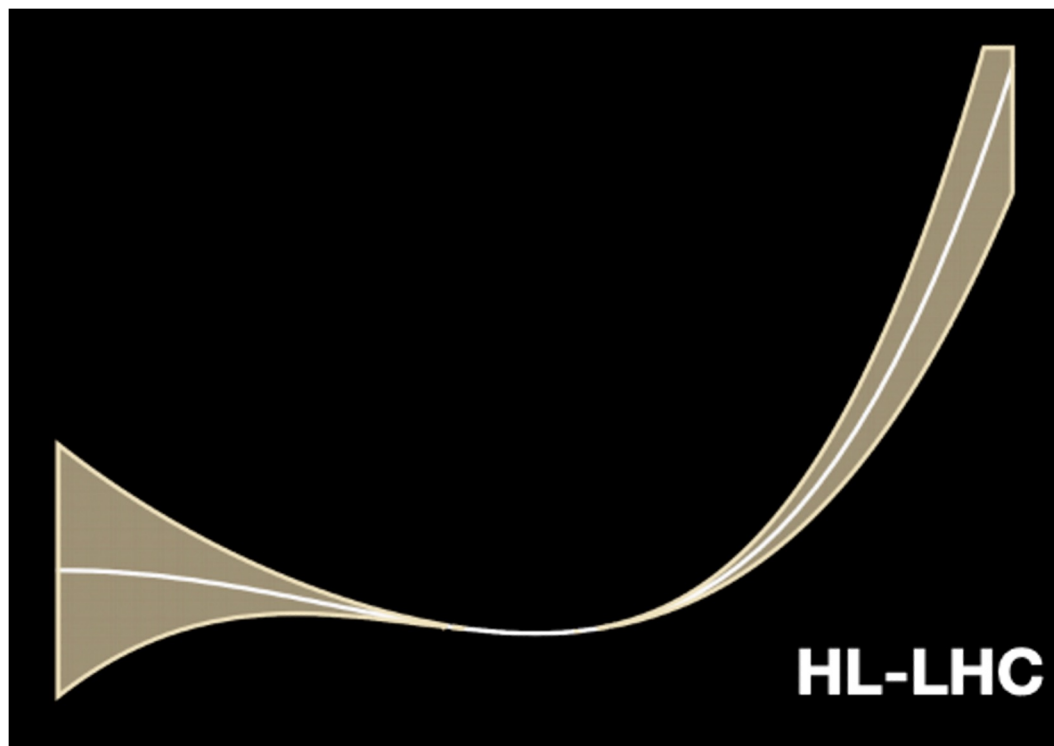

Flagship physics program to carry out measurements of λ_{HHH}

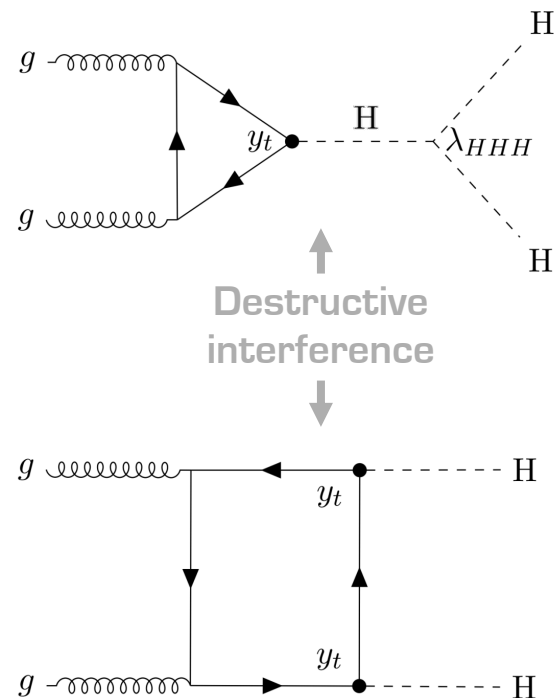

The Energy Frontier: μ Collider

Diagram:
Nathaniel Craig

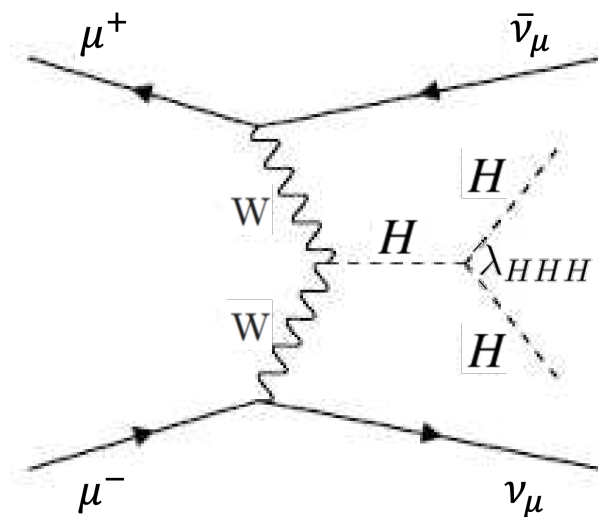
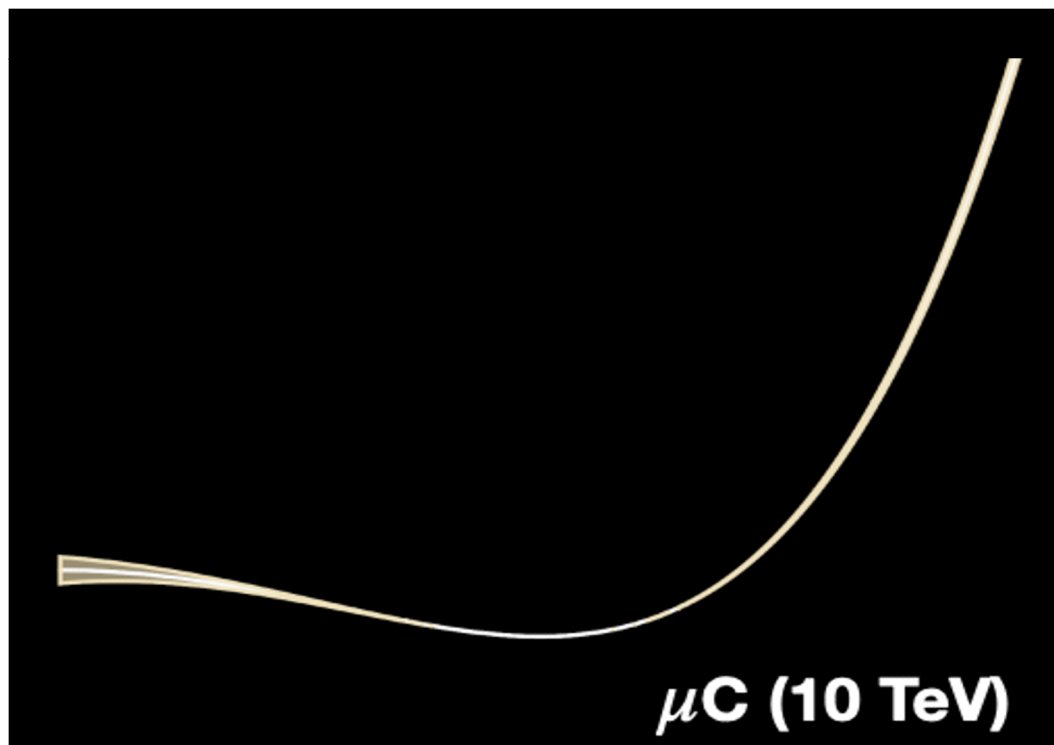

With the $\mu^+ \mu^- \rightarrow \nu_\mu \bar{\nu}_\mu HH$ process at high energies, we can reach **5% precision** for measurements of λ_{HHH}

My Postdoc Research Prong #1

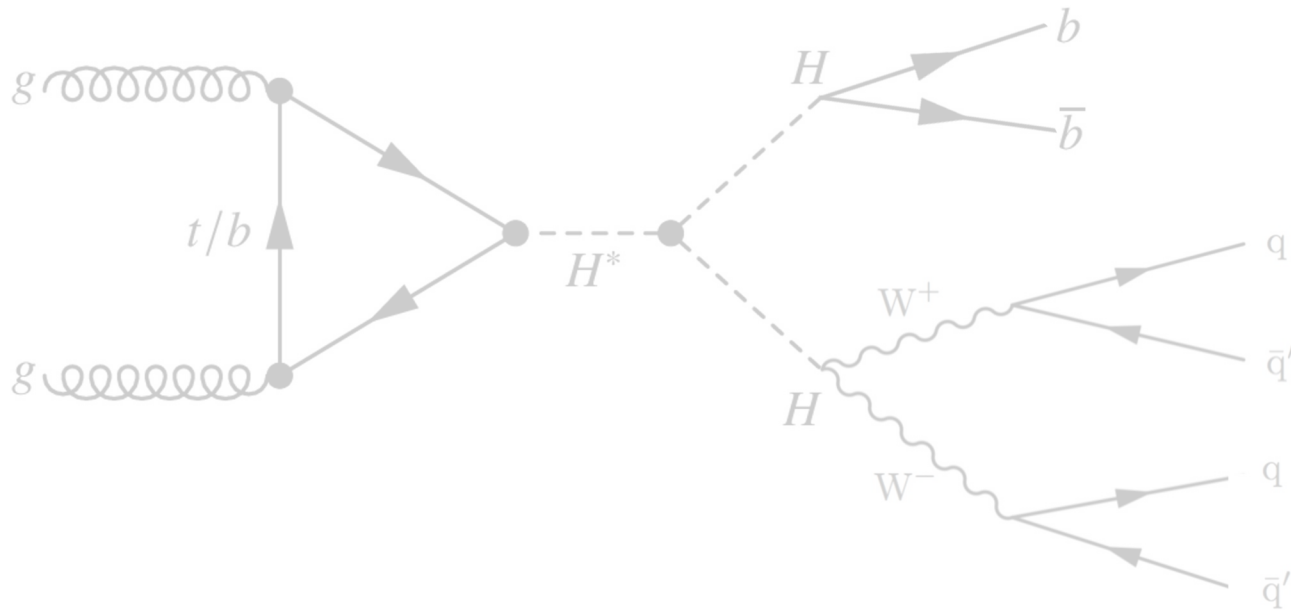
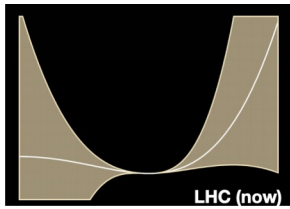

Search for $HH \rightarrow bbWW$ in the All-Hadronic Final State with Resolved Jets

My Postdoc Research Prong #2

**Cassette Assembly & Testing for the
High Granularity Calorimeter Upgrade**

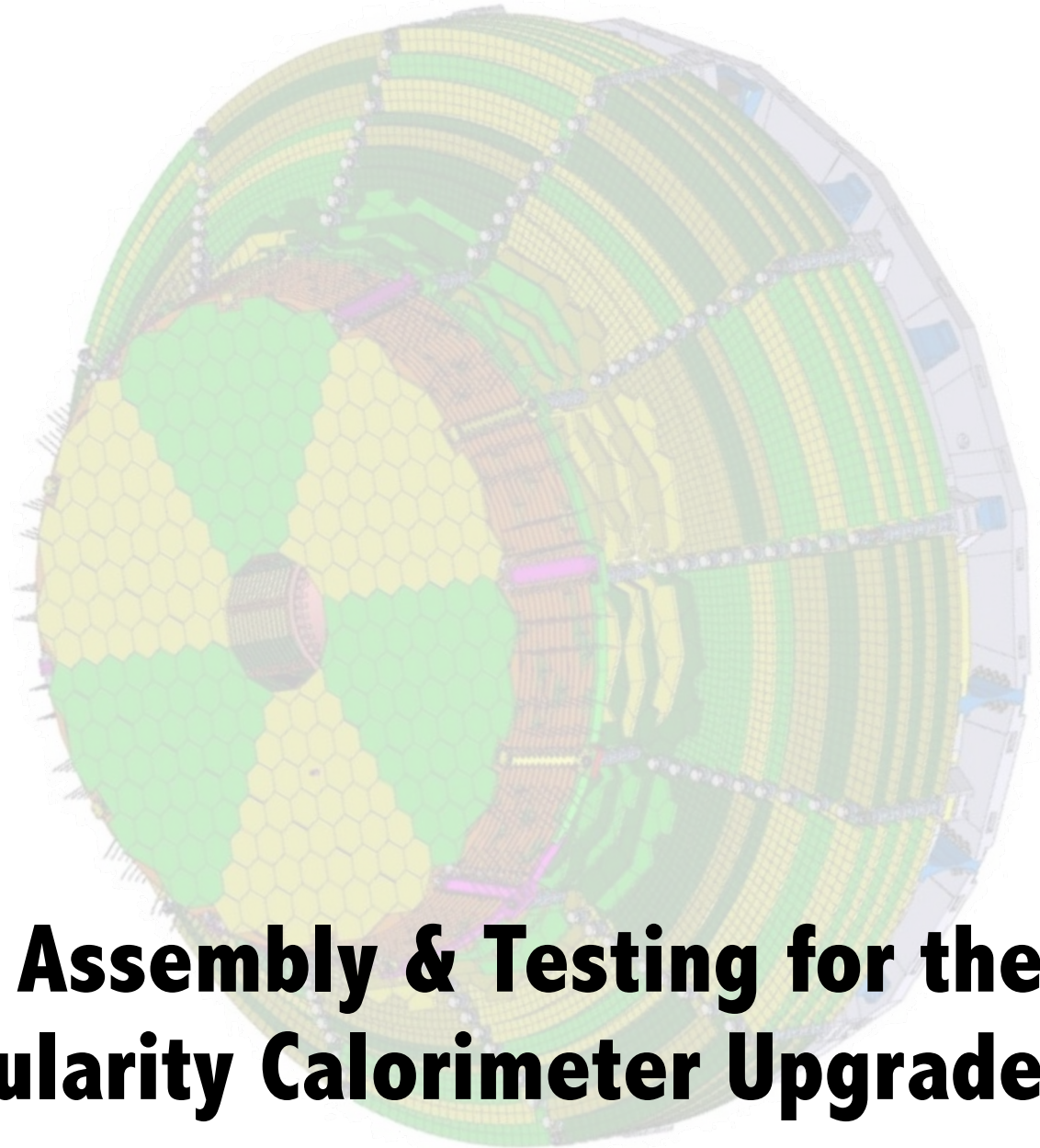

HL-LHC

My Postdoc Research Prong #3

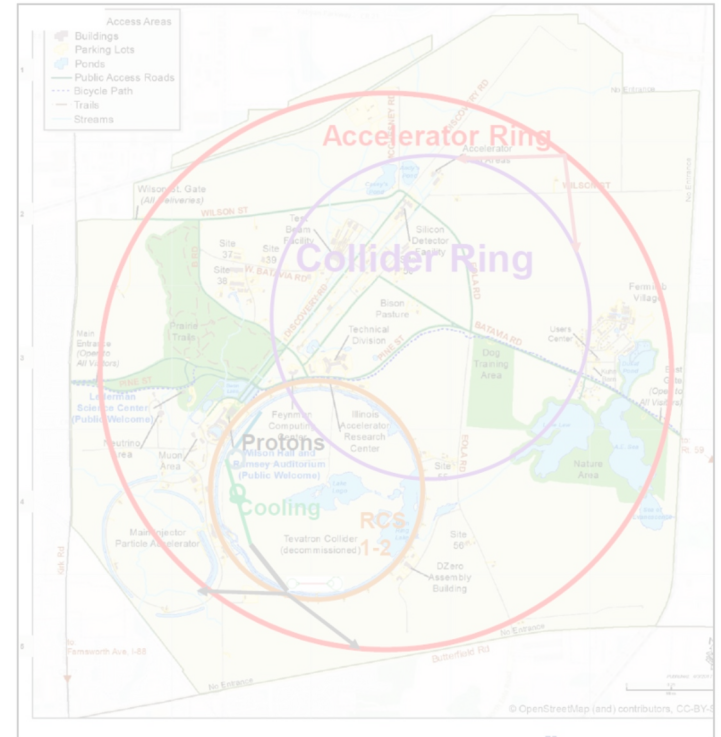
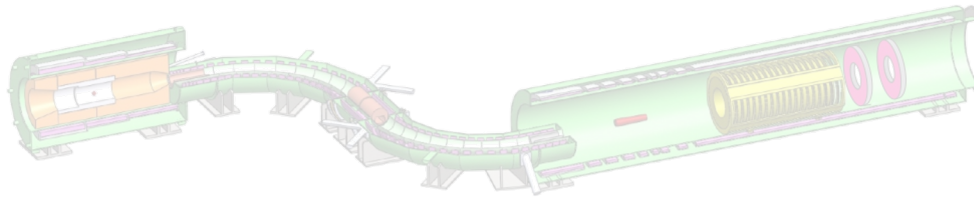
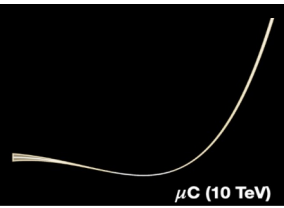

**Beamline Instrumentation & Simulation
for Mu2e and the μ Collider Demonstrator**

Thoughts For Grad Students In Years: 1 - 3



- Apply for **external funding** whenever possible
 - Don't take rejections personally — I was rejected from 3 - 4 fellowships before I got the LPC Graduate Scholar fellowship
 - It was a lot easier after that — awards lead to other awards!
- Talk with as many people possible — **networking** is super important
- Taking classes, TA-ing, and doing research are **very time consuming** — it does get easier when you're just doing research
- Take **initiative** — this is *your* degree and your research, don't wait on others
- Technical skills and physics knowledge will come over time. But do be very intentional about improving your **communication skills**
 - Presentations: improve your speech and **public speaking** skills
 - In general: practice meeting people **exactly where they're at** when you talk to them about your work. Your communication to a HEP professor, to a HEP grad student, to your experiment-specific collaborator, to a professor in another field in STEM, to a general public adult, to a pre-med undergrad, to a middle school student... should all be different



Thoughts For Grad Students In Years: 4 -

- When should you start thinking about applying for postdocs?
 - Generally: ~1 year from finishing
 - But really: when your advisor says it's ok for you to do so
 - Getting a postdoc can accelerate you finishing the PhD!
- Think carefully about your **letters** — besides your advisor, aim for collaborators in other institutions
- Set **standards** for yourself on the kinds of postdoc or jobs in general you want to pursue!
- Postdoc fellowships generally open in the fall, with a plethora of other HEP postdoc positions throughout the year (AJO, Inspire HEP, word of mouth)
- **A positive attitude, enthusiasm, and confidence** (healthy amounts of them of course lol) go a long way
- Take the time to get a big picture view of the field — as a postdoc, you're not just doing the research but **crafting** your research path forward. Having a **big picture vision of the field** and how you fit in is important

An aerial photograph of a university campus during sunrise. The sun is low on the horizon, casting a warm glow over the scene. In the foreground, there is a dense forest of green trees. In the middle ground, a large, modern, white building with a distinctive curved facade stands prominently. To its left, a large, irregularly shaped lake reflects the sky. The background shows a vast, hazy landscape under a clear blue sky.

Q & A